

QUICK USER GUIDE



EQ V.7–V.7 pro

TABLE OF CONTENTS

Specification	3
A brief description interconnections	4
Display menu	5
Microphone connection	6
Phantom power 48V	7
Level Setting, Button Level	8
Equalizer settings	10
Echo/Delay/Roger Setting	11
Bypass / Normal / Dx	12
Some practical setup	13
EQ V.7 pro description	14

EQ V.7

10 Band Equalizer - Compressor - Limiter - Echo - Delay - Roger with Noise Reduction function.

Specification

- ◇ ADC/DAC resolution 24 Bits
- ◇ Audio bandwidth 5 kHz (HF Firmware), 8kHz (CB Firmware)
- ◇ Mains hum suppression (50Hz & 60Hz) - >30dB
- ◇ Input: switchable with the ability to turn on bias voltage for the microphone
- ◇ Microphone amplifier: Two independent, one with a balanced input, the second with an unbalanced input. Adjustable gain 0 + 40dB
- ◇ An additional option is the Integrated + 48V phantom power supply for the Condenser Microphone (maybe in the range of + 35 + 48V, does not affect the operation of the Condenser Microphone)
- ◇ Microphone available: Electret, Dynamic, Condenser (optional)
- ◇ Adjustable squelch threshold with the ability to disable
- ◇ Compressor for **NORM** mode: Ratio adjustable 10:1; Treshold 0-40db; Attack - 1ms; Release - 50ms; Hold - 15ms.
- ◇ For **DX** mode software connected limiter (will be described below)
- ◇ Up to 200mV output level
- ◇ Up to 2 x 30 mW (32 Ω load) “MON” output power
- ◇ 10-band graphic equalizer with center frequencies:
90/150/220/350/500/800/1300/2000/2900/4500 Hz (HF Firmware)
100/150/250/400/650/1000/1700/2700/4400/7800 Hz (CB Firmware)
- ◇ Equalizer level adjustment range ± 12db
- ◇ Switchable processor Echo effects with Delay and Echo mode. Adjustable level 0-24db, duration 20—140ms
- ◇ Roger function with 600Hz sine wave, 50ms
- ◇ Three operating modes: Bypass / Normal / DX
- ◇ PTT function
- ◇ Accepted for Up / Down functions (not for all transceivers)
- ◇ Indication of Input signal level/ Compressor level (3dB step)
- ◇ Control — touch and with the help of rotation / pressing the encoder
- ◇ Supply voltage — 4.5 - 5.5V
- ◇ Current consumption — 200mA (max peak 1A)
- ◇ Maximum dimensions of the case - 127 x 85 x 85 mm (without cable and connectors)
- ◇ Weight — 0.63kg (1.4lb)
- ◇ User interface based on uGUI library

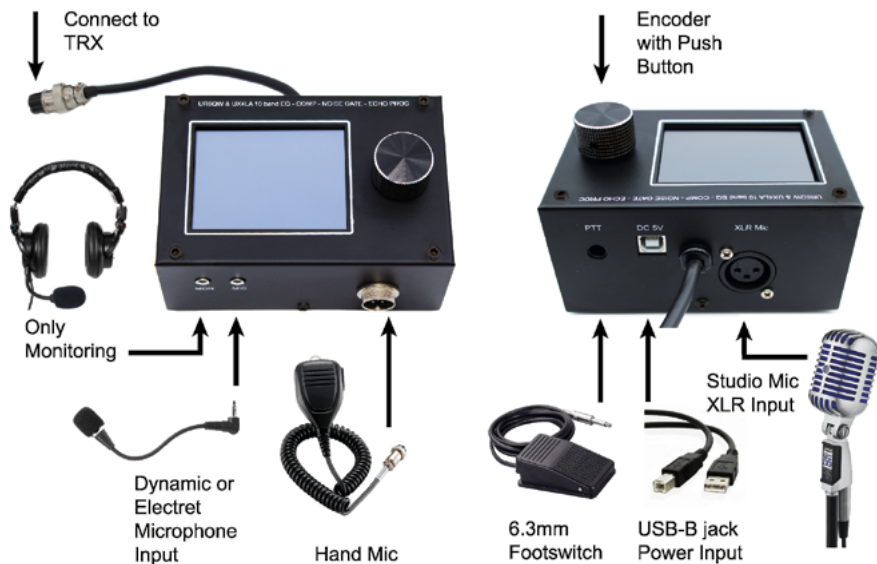

Figure 1

A brief description interconnections

The EQ V.7 is a versatile sound processor. You can connect any microphone to it (even a Condenser one requiring 48V phantom power) and make your studio-quality signal.

The device has two independent low-noise microphone amplifiers with two independent inputs for various types of microphones. The first amplifier has an unbalanced input, this is a 3.5mm jack on the front of the unit, signed **"MIC"**. You can connect an Electret or Dynamic Microphone to it. The Bias + 3V power supply can be disabled via the menu (the procedure will be described below).

The second amplifier has a balanced input, this is an **XLR socket on the back of the unit**, signed **"XLR Mic"**. It is intended for connecting high quality studio microphones, Dynamic or Condenser (optional, for condensers biasing a + 48V Phantom power board is required).

To the left of the **"MIC"** jack is the **"MON"** jack, with the same 3.5mm jack. This is an audio output to which you can connect headphones and check your signal generated by EQ V.7. Attention!!! This line does not transmit audio from the transceiver! Please note that on the air your signal may sound different from the

"MON" output, depending on the filters and transceiver settings!

8 pin male connector (4 - 7 pin optional) — this is the input for the standard hand mic. All unused lines are duplicated to the device output - Socket 8 pin female (4-7 pin optional) on the cable, which must be connected to the transceiver.

6.3mm socket on the back, signed **"PTT"** — for connecting the pedal. In the device on the PTT bus there is a key that performs a delay in TX mode when the pedal is released, if the Roger function is on. At the same time, a Roger signal with a frequency of 600 Hz is sent to the air.

USB-B jack this is an input for connecting power via a USB cable. You can use various power sources that provide a voltage in the range of 4.5—5.5V and a current of at least 300mA. Caution, do not use power sources that interfere with your reception!

Display menu

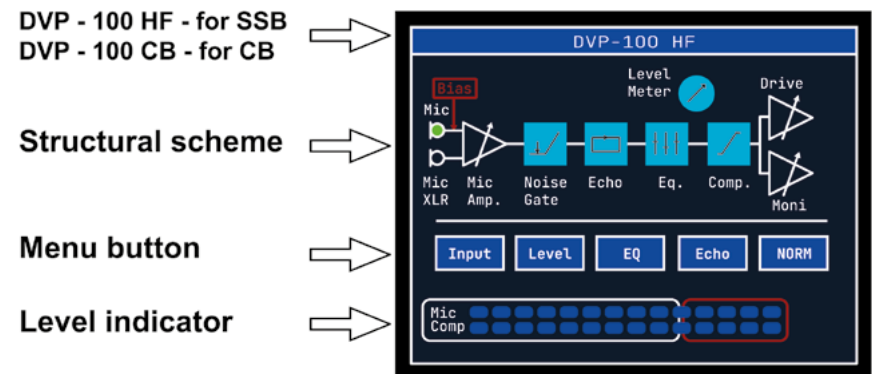

Figure 2

Figure 2 shows a photo of the main menu of the device. At the top of it is the firmware designation for the SSB ("DVP—100 HF") or CB ("DVP—100 CB") band.

Below is a simplified block diagram that gives a visual representation of how the circuit works as a whole.

In the middle part there are submenu buttons (Menu button).

In the lower part there is an indicator of the input signal level, before compression (Level meter) and Compressor level.

The complete block diagram has many input / output filters, phase shifter, limiter, etc. with a lot of subtle and complex settings that are not accessible to the user and are chosen optimal for most of the input signals. This is done in order to configure the device by the user as simple, effective as possible and exclude the possibility of spoiling the signal if you do something wrong!

The first time you turn on the device. Microphone connection.

Connect the main cable of the device to the transceiver in Figure 1 marked "Connect to TRX". Connect a microphone or handmic to the device. If necessary, connect the pedal (6.3mm jack on the rear panel).

Disable in transceiver standard Compressor and Equalizer!!!

Connect the USB cable to the device and to a 5V voltage source. The device is connected with a USB cable to any 5V source (computer, USB power supply, Power Bank, adapter 12 > 5V, etc.).

By pressing the submenu button Input, select the desired microphone input.

Mic — unbalanced input for connecting a Dynamic microphone jack - 3.5mm, handmic - 8 (6/5/4) pin connector.

Mic - Bias — unbalanced input for connecting an electret microphone - 3.5mm jack, hand mic - 8 (6/5/4 ..) pin. Attention - in this mode, there is + 3V voltage on the 3.5mm jack.

Mic XLR — balanced input for connecting a Dynamic Microphone, connector - XLR

Mic XLR - Bias — balanced input for connecting a Condenser microphone, jack - XLR. Attention in this mode, the + 48V voltage on the XLR input jack..

To enable this mode (the optional + 48V converter board must be installed in the device), it is necessary to turn off the power to the device, unscrew the 4 screws, remove the lower part of the case and set the switch to the Bias position as shown in Figure 3. After that, reinstall the lower cover (cut out to the XLR socket) and tighten the 4 screws.

Connect a microphone to the XLR jack and only then apply power to the device!

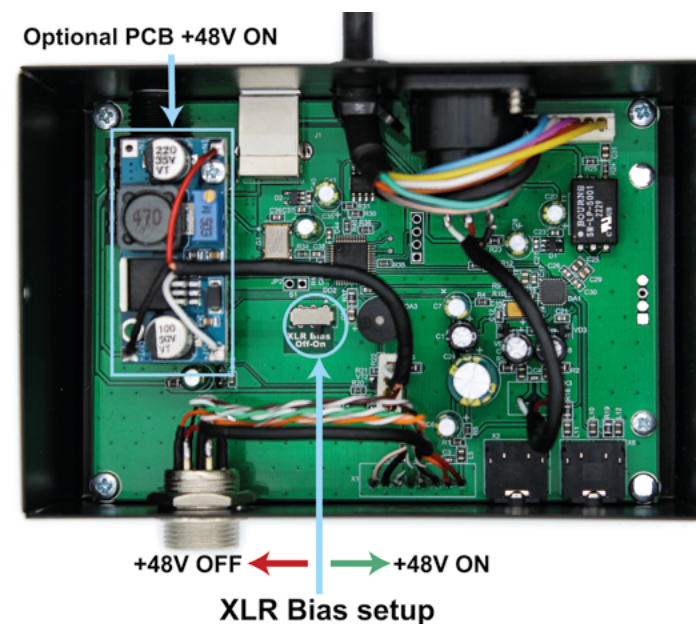
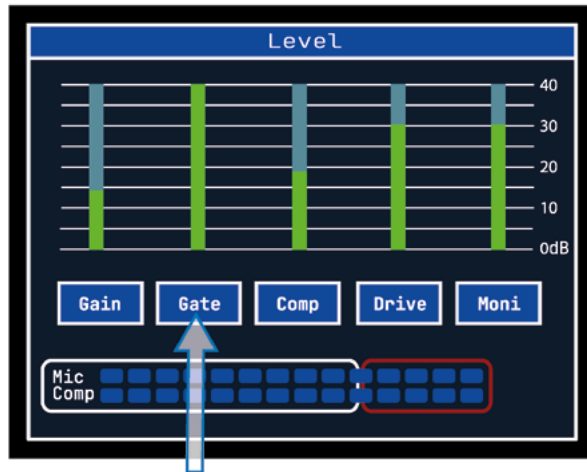

Figure 3

Attention!!! Never connect a Dynamic Microphone to the XLR input, if you have Mic XLR Bias turned on, it can kill your microphone! Never plug or unplug the Condenser Microphone while the device is on, first turn off the power of the device !!!

Level Setting, Button Level

Press button Level to enter the submenu. You will see the following picture:



Gate disabled
when the green line is at the very top

Figure 4

The **green** vertical indicators show how large the parameter is. In arbitrary units, the range 0-40db is indicated on the right side of the display.

To activate the button, you need to press it on the touch screen (highlighted in yellow), to configure - rotate the encoder. To exit to the main menu and save the current settings, click on the encoder.

Gain — adjusts the gain of the microphone. Where 0db is the minimum gain, 40 is the maximum. Keep the microphone in working position, select the distance to your mouth the way you work on the air. Click the Gain button. Speak into the microphone and turn the rotary encoder knob to change the gain level of the microphone amplifier. At the same time, monitor at the bottom of the display ("Level indicator"), the level indicator, which should be in the middle of the scale in the yellow-green sector (do not forget to speak into the microphone when setting up). The red sector is talking about congestion. A rare appearance of the

red sector is allowed with the loudest sounds:

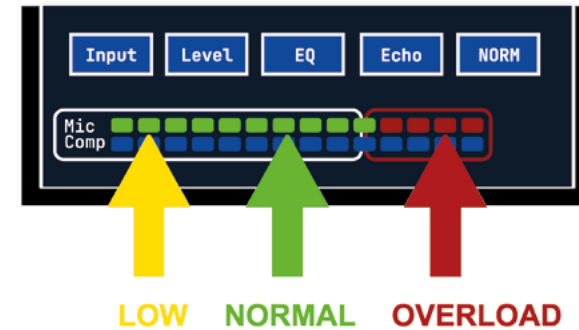

Figure 5

Gate — adjustment of the squelch threshold. Where 0db is the maximum limit of even very loud sounds, 39db is min. restriction, 40db - Gate is disabled and does not work. Gate needs to be configured at the very end of your experiments. Do not speak into the microphone, starting to set the Gate below 40db on a scale, the noise will begin to decrease, achieve a sufficient reduction in environmental noise. At the same time, some letters should not be cut off in the conversation. If this happens, raise the green Gate slider higher.

Comp — adjusts the compression level. Where 0db is 1: 1 compression, 35db is 10: 1 compression (maximum), 36db is 10: 1 compression, and an additional limiter with min. gain, 40db - 10: 1 compression and an additional limiter for max gain

Drive — adjusts the level of the output signal that is supplied to the transceiver. Drive settings must be made by speaking into the microphone and controlling the ALC level in the transceiver.

Moni — volume level control for headphone output, front panel 3.5mm "Mon" jack. This output is only needed for rough pre-setting of the device. Use it if your transceiver does not have monitor function.

After finishing the settings, click on the handle of the encoder to enter the main menu and save the parameters!

10-band equalizer settings

Press button **EQ** to enter the submenu. You will see the following picture:

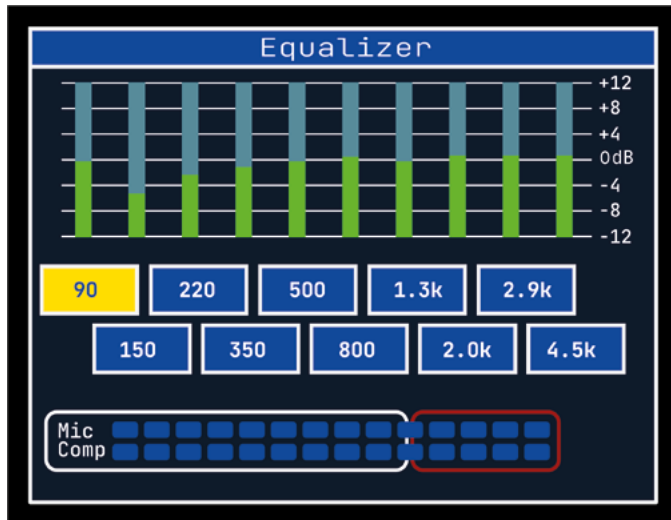

Figure 6

Press the button of the required frequency to change its value, it will be highlighted in yellow. Rotate the encoder to change the signal level, the adjustment range is -12 + 12dB.

If you have a device with firmware for the CB band (see Figure 2), the frequencies in the picture will differ. We specially released two versions of the firmware so that your signal would be really high-quality, since AM / FM modes has a wider band.

After finishing the settings, click on the handle of the encoder to enter the main menu and save the parameters.

It is recommended that after adjusting the equalizer, set the microphone preamplifier again (Gain button in the submenu **Level**), since the equalizer directly affects the gain.

Setting Echo/Delay/Roger

Press button **ECHO** to enter the submenu. You will see the following picture:

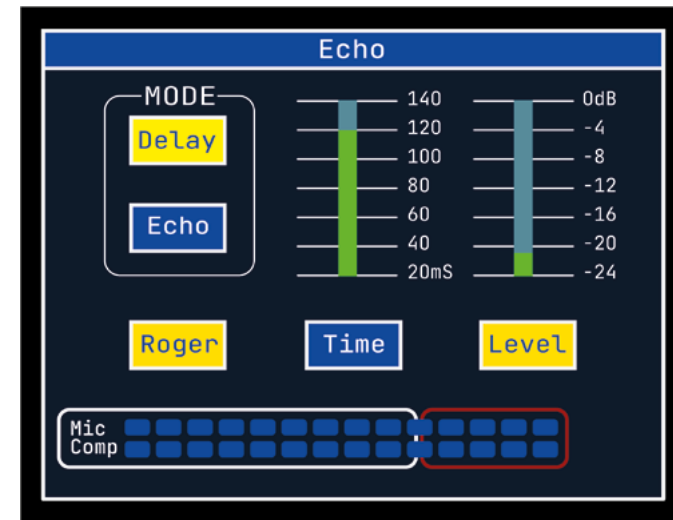

Figure 7

Echo — sound effect imitating clear fading repeats of the original signal.

To add Delay or Echo to the signal, you need to activate the needed button, it will be highlighted in yellow. To disable it, deactivate the Delay / Echo buttons accordingly - they should be highlighted in blue.

Delay — single repetitions.

Echo — multiple repetitions

Time — signal delay time in milliseconds

Level — the level of the Echo or Delay in the main signal in decibels. Where "0" dB - the level of the main signal and the echo are equal, "-24db" the level of the echo is 24db lower than the main signal..

Roger — a signal of the end of transmission with a frequency of 600 Hz. It will work when the Roger button is highlighted in yellow and a pedal or hand mic is connected to the device.

Attention!!! If you use TX switching on the transceiver side, the Roger function will not work.

After finishing the settings, click on the handle of the encoder to enter the main menu and save the parameters.

Bypass / Normal / Dx

Button **PASS** main menu turn on bypass mode. If the button is light in yellow, then the bypass mode is working, the signal from the microphone is go to the transceiver bypassing the signal processing by the device. In this mode, the microphone gain control function **Level > Gain**, the output level adjustment **Level > Drive** and **Level > Moni** will work

Button **NORM** — turn on Normal mode. The compressor work soft; limiter does not work; the filter band 5 kHz (8 kHz for CB).

Button **DX** — turn on DX mode. The compressor work harder; all time work limiter; the filter band narrows to 3.3 kHz (5 kHz for CB). Additional filter by input and additional filter by output are programmed. This removes whistling sounds and increases the peak level in the bandwidth, which very well increases the readability of the signal with a weak level on the receiving side.

Attention!! To save the settings, you need to go to the main menu before turning power off!

Some practical setup

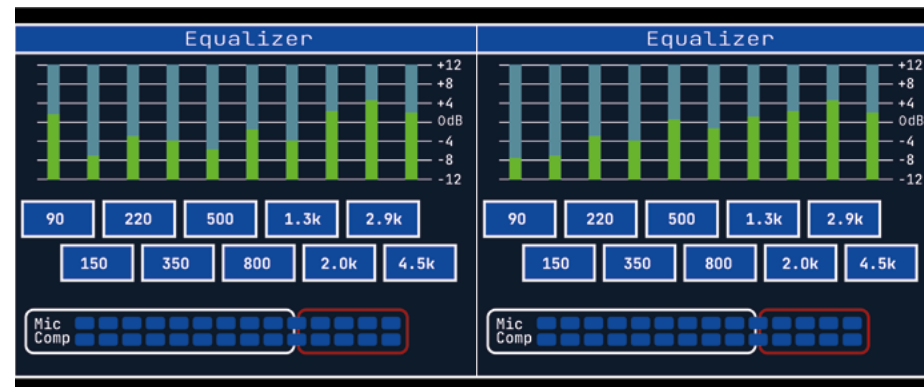

ESSB for electret Mic. Comp level 10-20dB **DX SSB** for electret Mic. Comp level 20-30dB

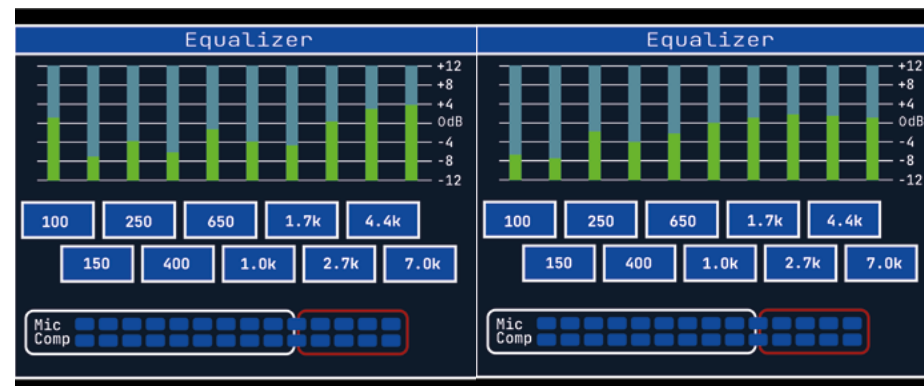

Ext CB for electret Mic. Comp level 5-10dB **DX CB** for electret Mic. Comp level 10-20dB

EQ setup may very differ depending on voice and microphone type

Attention! These settings are highly dependent on the type of microphone and your voice. They are given to make it easier for the user to first Equalizer setup.

EQ V.7 pro

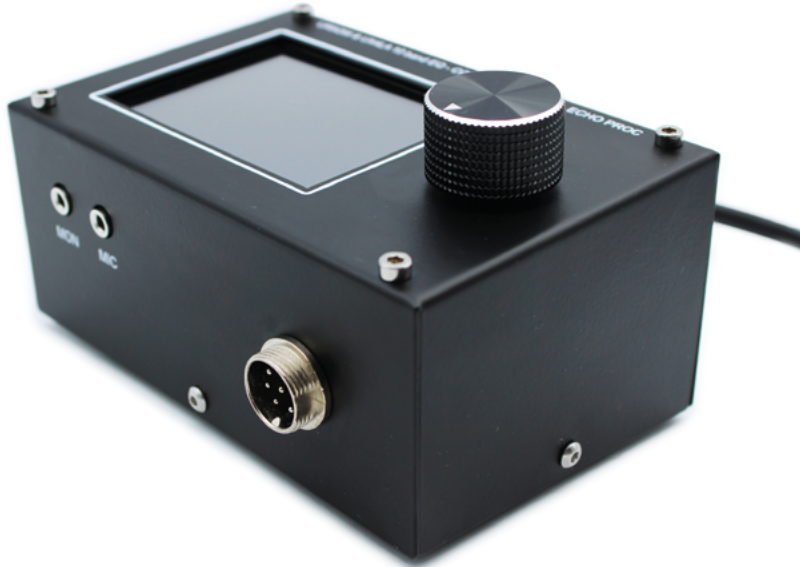

The **pro version** has the same specifications as the previous version, so only the differences will be described here.

- New touch screen calibration routine with errors checking and 5 points:

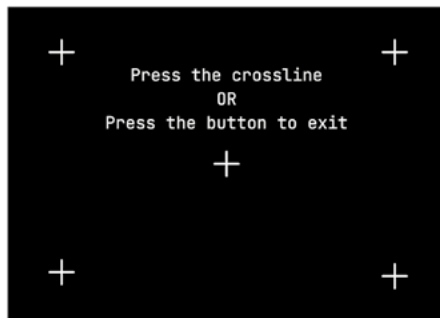

- Completely independent parameter sets for 4 various microphones type. The following parameters can be configured independently: **Gain/Gate/Comp/Drive/Monitor/Echo/Delay/Roger/Norm-DX-Bypass**
- More natural and smoother level and compression meters
- The enabled blocks in the signal chain are highlighted in color in the block diagram:

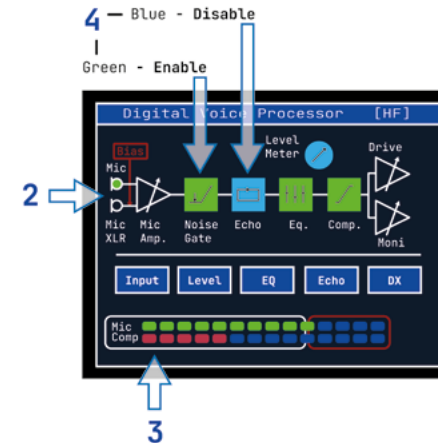

- Echo delay time increased to 150 ms
- Stulish metal knob and metallic screws

Very impotent, in this version Noise Gate disable when the indicator is at the bottom (in the normal version it's conversely):



Gate disable

UR6QW stores

Ukraine



DB6QW stores

Germany



User support: ur6qw.ua@gmail.com



EBAY stores

hfvhfparts



XADO Store



Ebay distributor: ux4la79@gmail.com